



DEFENDER

DEFENDER

PAKETTIAUTO

Defender-pakettiauto on täydellinen kumppani hankalimmillekin työmaille. Se ei jätä pulaan vaikeimmissakaan olosuhteissa, satoi sitten vettä, lunta tai räntää.

Defender-pakettiauton erinomaiset maasto-ominaisuudet ovat luokkansa parhaimmat ja sen vetokyky on jopa 3 500 kg. Autossa on vakiona 360 asteen kamera, säädettävä ilma-alusta ja polttoainetoiminen lisälämmitin. Auto on alv-vähennyskelpoinen ja myös alennetun autoveron alainen. Defender-pakettiauto on saatavilla 90 ja 110 -malleina ja voit valita itsellesi sopivan 2- tai 3-paikkaisen version.

- Saatavilla 2- tai 3-paikkaisena
- Vakiona 360 asteen kamera, säädettävä ilma-alusta ja polttoainetoiminen lisälämmitin
- Jopa 3 500 kg vetokyky



DEFENDER

KEVYT MAASTOKUORMA-AUTO



- Saatavilla 5- tai 7-paikkaisena
- Moottorivalikoimassa 6-sylinterinen diesel tai bensa V8
- Vetokyky 3 000 kg

Tilava ja tyylikäs Defender kevyt maastokuorma-auto omaa voittamattomat maasto-ominaisuudet. Tämän voimakkaan auton vetokyky on jopa 3 000 kg.

Tarpeistasi riippuen, voit hankkia Defender kevyt maastokuorma-auton 5- tai 7-paikkaisena ja moottorin osalta voit valita joko 6-sylinterisen dieselin tai V8 bensiinimoottorin. Defender kevyt maastokuorma-auto on alv-vähennyskelpoinen koko auton hinnasta. Auto on saatavilla Defender 130- tai 110-malleina.



POWERTRAINS

Defender is available with a wide range of powertrains, including a plug-in electric hybrid (PHEV) and a range of advanced and efficient Ingenium petrol and diesel engines with Mild Hybrid Electric Vehicle (MHEV) technology. The advanced P400e plug-in electric hybrid powertrain promises silent, zero tailpipe emissions driving in EV-mode for up to 27 miles and overall CO₂ emissions from just 74g/km¹.

The advanced P300e electric hybrid powertrain uses a 2.0-litre four-cylinder Ingenium petrol engine combined with a 105kW electric motor powered by a 19.2kWh prismatic cell lithium-ion battery for a combined power output of 300PS. The P300e delivers 0-100km/h in 7.6 seconds and fuel economy of up to 3.2l/100km¹.

Available on Defender 110, the P300e powertrain offers a new Defender experience and new dimension of adventure. With 625Nm of torque, it is also the only PHEV on the market with high and low range gears that can be driven exclusively in all-electric mode in low range.

The P300e operates in one of three driving modes. Hybrid is the default driving mode and combines petrol and electric power for optimum efficiency. Save mode holds the battery charge status so it can be deployed later in a journey, for example in urban areas, while EV mode runs solely on electric power for up to 51km¹ with zero tailpipe emissions. Regenerative braking recuperates charge to top up the battery for short periods of EV operation.

When the vehicle needs charging, a standard Mode 3 cable plugged into a 7kW public or domestic wall box will charge the battery to 80 per cent in as little as two hours, while a standard domestic socket and a Mode 2 charging cable will charge to the same level in seven hours. If using a rapid DC charger, it takes just 30 minutes to charge to 80 per cent.

Diesel power comes from a choice of powerful and efficient in-line six-cylinder D200, D250 or D300 Ingenium engines. The D200 delivers 500Nm of torque and 0-60mph in 9.5 seconds (0-100km/h in 10.2 seconds) for the Defender 110, with fuel consumption of up to 32.2mpg (8.8l/100km)¹. The more powerful D250 returns the same economy figures and a boost in torque to 570Nm, contributing to 0-60mph in 7.9 seconds (0-100km/h in 8.3 seconds).

DEFENDER



INCOMPARABLE, UNSTOPPABLE:

An icon reimagined for the 21st century available in three body designs with space on board for up to eight to travel in superior comfort

DESIGNED WITH PURPOSE, ENGINEERED TO EXCITE:

Clever and characterful with an instantly recognisable silhouette that features signature Defender elements across 90, 110 and 130 body designs

LOOKS TOUGH, IS TOUGH:

Durable D7x architecture engineered to withstand the Extreme Event Test procedure, above and beyond the normal standard for an SUV

WORLD-CLASS EXPERT OFF- AND ON-ROAD:

New Defender redefines breadth of capability - all-terrain ability is beyond question and on-road comfort adds to its unique character

SAFETY BY NUMBERS:

New Defender 110 has maximum five-star Euro NCAP safety rating, scoring 85 per cent for Adult and Child Occupant protection and 79 per cent for Safety Assist

EXPEDITION-READY:

A maximum payload of up to 900kg, static roof load of up to 300kg, dynamic roof load of 168kg, towing capacity of 3,500kg and wading depth of up to 900mm make Defender the ultimate 4x4 for overland adventures

INNOVATIVE OFF-ROAD TECH:

Pioneering Terrain Response 2® includes Wade programme and off-road Configurable Terrain Response, so experts and novices can optimise traction in all conditions

INTELLIGENT ALL-WHEEL DRIVE:

Advanced All-Wheel Drive system optimises on-road performance, economy and off-road capability

ON-ROAD COMFORT:

Defender is composed on any road surface with supreme comfort ensuring long journeys are covered with ease regardless of the conditions

EFFICIENCY AT ITS HEART:

Electrified powertrains include advanced mild-hybrid and plug-in electric hybrid options, as well as powerful and efficient Ingenium petrol and diesel engines

FIVE- OR SIX-SEAT ELECTRIC HYBRID

POWER MEETS CAPABILITY:

Potent P525 V8 powertrain packs 625Nm of torque and brings new levels of performance and handling to Defender, with 0-60mph in as little as 4.9 seconds (Defender 90)

SIX-CYLINDER POWERTRAINS:

In-line six-cylinder Ingenium petrol and diesel engines with MHEV technology available with superior smoothness and efficiency

21ST CENTURY TECHNOLOGY:

Pivi Pro infotainment features an intuitive interface while Software Over The Air technology provides the latest software at all times, anywhere in the world

WHAT3WORDS NAVIGATION:

New Defender can find and navigate to any 3m square on the planet, without the need for a phone signal, using the advanced Pivi Pro infotainment system

REDUCTIONIST, PURPOSEFUL INTERIOR:

Functional, durable and flexible interior is unique with exposed structural elements and optional centre front jump seat² - perfect for sharing adventures

MEET THE FAMILY:

110 available with 5+2 seating. New 130 provides space for up to eight people. Four distinct Accessory Packs (Explorer, Adventure, Country and Urban) over 100 accessories, plus heritage-inspired County¹⁴ Exterior Pack

SOPHISTICATED EXPLORER:

Defender 130 features distinct exterior and interior colours and materials, with standard air suspension, two sunroofs and Four-Zone Climate Control for enhanced comfort

ULTIMATE SPACE AND CAPABILITY:

New Defender 130 Outbound features a spacious five-seat configuration with vast load space for superior balance of space and all-conquering capability

CAPABLE OF GREAT THINGS:

Defender has the inner strength necessary to make great things happen. The champion of those with the courage to help where others dare not, or cannot, go

AN ICON REIMAGINED FOR THE 21ST CENTURY

Defender is an icon reimagined for the 21st century. It is clever, capable and safe for all the family, and in a category all of its own. Defender is built for adventurous hearts and curious minds, for those who know the value of community and strive to make a difference.

The unmistakable silhouette looks tough and is tough but designed with purpose and engineered to excite. Iconic in name, shape and capability, Defender can be personalised to allow owners to make the most of their world.

Across seven decades of pioneering innovation, the Defender has earned a unique place in the hearts of explorers, humanitarian agencies and adventurous families across the world. Proven in the harshest environments on earth, the Defender maintains this bloodline.

The compact 90, practical 110 and spacious 130 body designs, along with the new 5-seat 130 Outbound now make up the Defender line-up.

Driven by a passion and respect for the original, Defender delivers a transformational breadth of capability with space for up to eight on board. Advanced all-terrain technologies redefine adventure for the 21st century, remaining true to the pioneering spirit that has been a Land Rover hallmark for over 70 years.



EMOTIONALLY CHARGED DESIGN

A distinctive silhouette makes the Defender instantly recognisable, with minimal front and rear overhangs providing excellent approach and departure angles. Land Rover's designers re-envisioned familiar Defender trademarks for the 21st century, giving the 4x4 a purposeful upright stance and Alpine light windows in the roof, while retaining the side-hinged rear tailgate and externally mounted spare wheel that make the original so identifiable.

The stripped-back personality of the original Defender has been embraced inside, where structural elements and fixings usually hidden from view have been exposed, with the emphasis on simplicity and practicality. Innovative features include a dash-mounted gear shifter to accommodate an optional centre front 'jump' seat², which provides three-abreast seating across the front like early Land Rovers.

As a result, the Defender 110 offers five, six or 5+2 seating configurations, with a loadspace behind the second-row seats of up to 1,075 litres, and up to 2,380 litres when the second row is folded, while Defender 90 is capable

of accommodating six occupants in a vehicle the length of a compact family hatchback. Defender 130 offers exploration for up to eight adults across three rows (2+3+3) of seating – and a maximum loadspace of up to 2,516 litres, while the new Defender 130 Outbound exclusively offers five seats and a vast load area for ultimate adventures.

User-friendly features combine practical touches with advanced technological innovations. Durable rubberised flooring shrugs off the spills of daily adventures and once-in-a-lifetime expeditions on 90 and 110, providing a brush or wipe clean interior. The 130 features premium carpets to suit its unique and refined character, while the near flat floor of the Defender 130 Outbound means the full load space can be utilised for equipment and kit for any activity.

An optional full-length Folding Fabric Roof² – available on both Defender 90 and 110 – provides an open-top feel. It allows passengers in the second-row seats to stand up when parked to provide the full safari experience, while 130 models are fitted with a panoramic sunroof as standard, with a second sunroof above the third row of seats for a light and airy interior for every row.





THE DEFINITION OF DURABILITY

Defender's purpose-engineered D7x (for extreme) architecture is based on a lightweight aluminium monocoque construction to create a stiff body structure. It is three times stiffer than traditional body-on-frame designs, providing perfect foundations for the fully independent air or coil sprung suspension and supports the latest electrified powertrains.

Defender has been through more than 62,000 tests for engineering sign-off, while the chassis and body architecture have been engineered to withstand Land Rover's Extreme Event Test procedure - repeated and sustained impacts, above and beyond the normal standard for SUV and passenger cars.

During development testing, prototype models covered millions of kilometres across some of the harshest environments on earth, ranging from the 50-degree heat of the desert and sub 40-degree cold of the Arctic to altitudes of 10,000ft in the Rocky Mountains of Colorado.

Defender's legendary toughness is highlighted by the five-star Euro NCAP safety rating awarded to the 110. An 85 per cent score for adult and child protection and 79 per cent for Safety Assist helped it gain the maximum possible score in this benchmark assessment.

WORLD-CLASS EXPERT OFF- AND ON-ROAD

A transformational breadth of capability sets New Defender apart. All-Wheel Drive and a twin-speed automatic gearbox, centre differential and optional Active Locking Rear Differential ensure it has all the hardware required to excel in the soft sand of the desert, the freezing tundra of the arctic and everywhere in between.

The 525PS¹¹ Defender V8 builds on more than 40 years of Land Rover V8 heritage and features a unique specification and specially developed chassis set-up. Its Active Locking Rear Differential incorporates a Yaw Controller for even greater agility and unrivalled driver engagement.

Configurable Terrain Response allows experienced off-roaders to fine-tune individual vehicle settings to perfectly suit the conditions, while inexperienced drivers can let the system detect and deploy the most appropriate vehicle settings for the terrain, using the intelligent Auto function.

Its body architecture provides ground clearance of 291mm and world-class off-road geometry, giving the 110 approach, breakover and departure angles of 38, 28 and 40 degrees (off-road height) respectively. A maximum wading depth of 900mm for all body designs is supported by a new Wade programme in the Terrain Response 2[®] system, which ensures drivers can ford deep water with complete confidence.

On dry land, Land Rover's advanced ClearSight Ground View² technology helps drivers take full advantage of Defender's all-conquering capability by showing the area usually hidden by the bonnet, directly ahead of the front wheels, on the central touchscreen.

As a result, the New Defender redefines breadth of capability, raising the threshold for both off-road ruggedness and on-road comfort. It can negotiate crowded city streets as effortlessly as climbing mountains, crossing deserts and withstanding freezing temperatures. Its carefully honed handling delivers both a rewarding drive and first-class long-haul comfort across all terrains.



POWER AND EFFICIENCY

A choice of advanced four-, six- and eight-cylinder engines ensure Defender has the power, control and efficiency for any environment, while its Electric Hybrid powertrain provides silent EV-only progress of up to 27 miles¹ - unique in a plug-in electric hybrid vehicle with the Defender's off-road capabilities.

The powerful Defender V8 features a 5.0-litre V8 supercharged engine and is the fastest, most powerful and dynamic production Defender ever made, with 525PS in the Defender 90 V8 and Defender 110 V8, and 500PS in the Defender 130 V8.

Alternatively, customers can choose an in-line six-cylinder diesel - the D300 - providing a muscular 650Nm of torque. For ultimate choice, this powertrain is also available in D200 and D250 variants, also featuring MHEV technology for superior responses and enhanced efficiency.

Defender features Intelligent All-Wheel Drive, which is the product of years of development. The advanced set-up provides enhanced on-road performance and balance, as well as responsive and unstoppable off-road capability. The intelligent torque distribution system optimises the driveline for traction, on-road dynamics and driveline efficiency, resulting in improved fuel economy and reduced CO₂ emissions - all without sacrificing any of the Defender's inherent off-road capability.

Innovative engineering solutions support the efficiency drive, including a flat underbody which both optimises aerodynamic performance (as low as 0.38Cd) and protects the vehicle's underbody.





21ST CENTURY TECHNOLOGY

Defender is as technologically advanced as it is durable. Land Rover's Pivi Pro infotainment is available with a choice of 10-inch and 11.4-inch² touchscreen displays. The intuitive and user-friendly system requires fewer inputs to perform frequently used tasks, while the always-on design guarantees almost instant responses.

Defender now features the global location platform, what3words, giving customers accurate and precise navigation even in the most remote environments. British technology company what3words has divided the globe into a grid of 57 trillion 3m x 3m squares, each with a unique, easy-to-remember three-word address.

The integrated technology allows what3words addresses to be inputted directly to the navigation bar on the Pivi Pro Infotainment or via the connected car app, working seamlessly alongside the existing HERE connected navigation and mapping software.

Customers are able to navigate precisely to any location in the world, faster and more conveniently than ever using just three words - whether finding the perfect place to explore off-road, locating an individual parking space or identifying a specific entrance.

In addition, the Defender takes Software Over The Air (SOTA) technology to a new level, with multiple modules capable of receiving remote updates. By downloading data while customers are asleep at home or in far-flung locations, the New Defender will get better with age: as electronic updates cascade down to the vehicle immediately, without delay and with no need to visit a retailer.



PERSONALISED FOR YOUR WORLD

Defender is available in 90, 110 and 130 body designs, with up to six seats in the 90 and the option of five, six or 5+2 seating in the 110. The New Defender 130 provides adventuring opportunities for up to eight adults across three rows of full-size seating in a 2+3+3 arrangement, while the Defender 130 Outbound maximises the interior space made available by the 130 body design with five seats and an expansive load area.

The core model range comprises Defender, Defender X-Dynamic and Defender V8. Defender V8 represents the performance pinnacle of the

4x4 family.

Defender X-Dynamic, in addition to Defender models, can be enhanced with a choice of S, SE and HSE specifications.

Customers are able to further personalise their vehicle with four Accessory Packs. The Explorer, Adventure, Country and Urban Packs¹ each give Defender a distinct character with a specially selected range of enhancements, with Black Pack additions available for Explorer and Adventure Packs.

Defender 110 can also be specified with a new County¹⁴ Exterior Pack. Inspired by an iconic Defender livery, it provides a modern interpretation with three distinct colour combinations, enhanced by unique County decals and finishes.

The New Defender 130 is available in S -Dynamic specifications. At the pinnacle of the line-up is the Defender 130 V8 with a unique specification similar to Defender 90 and 110 V8 derivatives. The largest member of the Defender

family has grown to include the New Defender 130 Outbound, exclusively featuring five seats and a spacious load area, with unique exterior elements that define it as the ultimate interpretation of the most capable and spacious model in the family.

The Satin Protective Film can be specified to make the exterior paintwork even more durable. The wrap helps protect against everything from car park scratches to bramble rash and is available as a factory-fit option in Gondwana Stone, Pangea Green and Eiger Grey, providing a contemporary finish as it protects the Defender's paintwork.

Defender is also available with the widest choice of individual accessories ever assembled for a Land Rover, with everything from a Remote Control Electric Winch, Rooftop Tent⁹ and Inflatable Waterproof Awning, to more conventional tow bar systems and roof racks.



EXTERIOR DESIGN

Defender's characterful front is tough but approachable, emphasised by the geometric forms of its highly technical headlamps which feature the latest adaptive technology, while beautifully sculptured fenders combined with squared wheel arches and strong shoulders all contribute to the vehicle's sense of solidity and robustness. At the rear, the geometric forms of the distinctive high-tech lamps harmonise perfectly with the front-end design.

The sheerness of the rear maintains the short overhang on the 90 and 110 for a superior departure angle while maximising interior space and accentuating the vehicle's strong shoulder section. Every detail of the exterior design has been creatively developed to re-enforce Defender's DNA; sophisticated, durable and extremely tough, a vehicle design like no other.

For the 130, Defender's iconic silhouette is elegantly extended by 340mm at the rear to provide enhanced interior space. It is identical to the 110 ahead of the rear passenger door and engineers have crafted a subtle boat tail-style uplift that maximises the unparalleled all-terrain capability customers expect from Defender, providing a departure angle of 28.5 degrees³.

The surrounds for the rear LED lighting units were re-engineered to maintain the three distinct lines that define Defender's side profile as they rise subtly towards the rear.

“The clean body side contrasts dramatically against the sheer verticality of its front and particularly its rear to create a reassuringly purposeful stance. The overall impression is of an elemental design, yet this clean reductive approach is underpinned by sophisticated surfacing of the highest quality.”

Prof Gerry McGovern OBE, Chief Creative Officer, Land Rover



DEFENDER V8

Defender V8 sits at the performance pinnacle of the line-up, where power meets capability and durability meets refinement. Featuring bespoke exterior enhancements, the Defender V8 has a unique high-performance character and heightened driver appeal. Instantly recognisable, it features bespoke exterior badging, quad rear exhausts and 22-inch alloy wheels with a Satin Dark Grey finish.

Defender V8 is further identified by its Xenon Blue brake calipers and high-performance 20-inch brakes, and is available across 90, 110 and 130 body designs. Customers have a choice of Carpathian Grey and Santorini Black. Carpathian Grey is available with a contrast roof in Narvik Black. Shadow Atlas exterior detailing completes Defender V8's distinctive exterior.



Defender 130 has its own colour palette, including a new, exclusive Sedona Red option. Its refined proportions are enhanced by the optional Extended Bright Pack. In this specification, all lower body panels are finished in Ceres Silver Satin, providing a distinctive appearance on vehicles finished in Hakuba Silver and Fuji White.

Ceres Silver detailing can be found on the bonnet louvres and side fenders of all Defender 130 models, perfectly complemented by 20-inch Luna alloy wheels, which are available in a Bright Silver finish. Narvik Black roof rails are fitted as standard on the 130 along with a body-coloured spare wheel cover, while Defender's full range of exterior accessory packs is also available.

The New Defender 130 is available in SE, HSE, X-Dynamic and X specifications, in addition to a First Edition model. It builds on HSE specification with an extensive equipment list including Matrix LED headlamps, heated second and third-row seating, Four-Zone Climate Control, Meridian™ Sound System, Driver Assist Pack and Privacy Glass.

The Defender 130 Outbound comes with its own exterior identity, featuring body-coloured signature panels in the rear quarter areas, with matching D-pillar finishers, plus front and rear bumper sections and grille inserts finished in Shadow Atlas Matt. The Satin Protective Film is available on Santorini Black, Carpathian Grey and Eiger Grey finishes, while Fuji White is also available.





SATIN PROTECTIVE FILM

Defender is available with a factory-fitted Satin Protective Film which delivers enhanced design and durability. The PU-based wrap is applied to external bodywork and gives the standard metallic paint a rich and contemporary satin finish, showing the sophisticated surfacing of the exterior design in the best possible light. This durable wrap meets rigorous standards and has been developed for the highest performance in extreme conditions.

The film can be removed at any time, making it significantly quicker to repair than standard paint finishes. It is available in Gondwana Stone, Pangea Green and Eiger Grey paint options, is solvent-free and contains no volatile organic compounds (VOCs).

A choice of 12-wheel designs is available, ranging from 18-inch white-painted pressed steel rims to 22-inch Luna alloys, finished in silver as standard, Dark Grey for X-Dynamic and Defender X derivatives, a Satin Dark Grey finish for Defender V8 models and Bright Silver for 130 body designs.

Body colour options include three metallic shades unique to the Defender with Tasman Blue, Pangea Green and Gondwana Stone joining Fuji White, Eiger Grey and Santorini Black, Hakuba Silver, Silicon Silver and Carpathian Grey. Defender 130 can be exclusively finished in Sedona Red.

A striking contrast roof option is available in a choice of white or black (or blue as part of a new County¹⁴ Exterior Pack), giving customers ultimate freedom to personalise their Defender².

COUNTY EXTERIOR PACK

The County¹⁴ Exterior Pack - globally available on Defender 110 - honours Defender's legendary lineage with a unique, modern aesthetic. It features County graphic decals on the body sides and doors, plus welcoming illuminated treadplates with County graphic.

The County¹⁴ Exterior Pack is available in three distinct body colour and roof combinations:

- Fuji White body with new Tasman Blue Contrast Roof and Tailgate, plus Tasman Blue gradient graphic decal and treadplate
- Santorini Black body with new Tasman Blue Contrast Roof and Tailgate, plus Tasman Blue gradient graphic decal and treadplate
- Tasman Blue body with White Contrast Roof and Tailgate, plus Fuji White gradient graphic decal and treadplate

There are two 20-inch wheel options to choose from, with a gloss white choice that embraces the County theme.



CONSTRUCTIVIST INTERIOR DESIGN

Defender's constructivist modular interior architecture communicates its highly functional nature, underpinned by its practical layout and reductive design.

This approach is most evident by the exposed, powder-coated magnesium Cross Car Beam which is integral to the overall strength of the body architecture. This structural die-cast magnesium alloy beam is available in a range of finishes and incorporates integrated grab handles to aid entry and for a secure grip during serious off-road driving.

The main controls, including the central touchscreen, are ergonomically clustered within the magnesium frame to enable the installation of an innovative optional front row centre seat² while also allowing for movement across the front of the cabin.

Practicality is a hallmark of Land Rover interior design and Defender comes with an abundance of storage opportunities including a choice of high and low centre consoles. The durable constructivist theme is consistent throughout the interior with visible fixings that retain the structural door casings while partially exposing the painted doors.

This pared-back design philosophy extends to the durable rubberised flooring in 90 and 110 which combines with flush door sills to provide genuine wipe or brush clean functionality. Other details include cast magnesium features, padded waist rails, grab handles and arm rests.



The innovative Front Row Centre Seat (otherwise known as jump seat²) allows three people to travel in the front row. Conceived and designed as an occasional seat, the practical addition means the Defender 110 can be specified with five, six or 5+2 seating. The short-wheelbase Defender 90 can accommodate six occupants in a compact family hatchback length body. When not in use, the seatback folds down to provide a front armrest and oddment stowage, including a pair of additional cupholders.

The new 130 can accommodate up to eight adults across three rows of full-size seating in a 2+3+3 arrangement. The elegantly extended rear creates uncompromised accommodation in the third row, with enough space for three adults to sit in comfort, while the Defender's familiar outline ensures generous headroom in all three rows.

Additional touches ensure a comfortable row-three passenger experience, including heated seats, padded armrests, thoughtfully designed oddment stowage and USB-C provision for charging devices on the move. Carpets are also fitted throughout to suit the 130's unique character.

Large windows provide excellent visibility in all three rows of seating while the standard-fit panoramic glass sunroof, which is complemented by a second sunroof above row three, makes the interior light and airy for all. Additional comfort is provided by ventilation for each row, with enhanced ducting providing extra heating and air-conditioning outlets and supporting Three and Four-Zone Climate Control.

Passengers in rows two and three also benefit from a small stadium rise, for superior visibility, while getting in to - and out of - the third row is effortless, as the row two seats slide and fold forwards to provide wide access. ISOFIX child seat attachments are available for up to five of the passenger seats; on the outer seats of the second and third rows, as well as the front passenger seat.





INTERIOR FINISHES

Comfort is a key part of Defender, with interior materials focused on retained newness - so even after thousands of miles of adventure Defender is sure to look and feel fresh. Customers can choose from a range of interior colour schemes with scope for personalisation, available by mixing these with different interior finish options.

HSE models feature high-grade Windsor Leather, while Defender X features Windsor Leather in combination with Steelcut Premium Textile accent for enhanced durability. This textile from Kvadrat is a 30 per cent wool blend and is also available as a full alternative to the leather upholstery paired with Miko Suedecloth.

An even more sophisticated cabin environment is provided in the 130, with Noble Chrome detailing on the air vent controls and electric seat switches, while speaker elements are finished in bright Ceres Silver and armrest hinges are finished in Atlas. Natural Light Oak engineered wood veneer lends a natural, modern look and feel, to elegantly complement the Light Oyster Perforated Windsor Leather seating.

Up front, Defender 130 features a larger 11.4-inch Pivi Pro touchscreen as standard following its introduction on Defender 90 and 110 V8, for enhanced control over the vehicle's core functions via a crisp and intuitive display. The curved glass interface provides fast, state-of-the-art functionality and responds as soon as the vehicle is started, with a simple menu structure.



CAPABILITY



DEFENDER

CAPABILITY

REDEFINING BREADTH OF CAPABILITY

The Defender has always been a symbol of strength and the new model is the toughest and most capable Land Rover yet, combining a new body structure with world-first technologies and proven hardware to create a Defender that is fit for the 21st century.

The lightweight all-aluminium monocoque construction of the new D7x architecture delivers a stiff body, with a torsional rigidity of 29kNm/Degree - making it three times more rigid than traditional body-on-frame designs. These strong foundations provide the perfect basis for the all-independent suspension, twin-speed transfer box and Intelligent All-Wheel Drive.

Configurable Terrain Response allows drivers to fine-tune the set-up of the vehicle to suit the precise off-road conditions like never before. The Terrain Response 2® system also includes a new Wade programme to provide the ultimate reassurance when driving through water by optimising all of the vehicle systems accordingly.

Delivering transformational breadth of capability and on-road handling, Defender is in a category of its own, further reinforced by the advanced P400e plug-in electric hybrid (PHEV) powertrain¹. It offers a unique adventure opportunity previously untapped by PHEV drivers and is in a class of its own when it comes to off-road capability delivered by a vehicle with a plug-in hybrid electric powertrain.

With 525PS¹¹ and a chassis tuned to provide elevated agility, Defender V8 is the most capable Land Rover ever made. It introduces a Dynamic program within the Terrain Response 2® system which is only available on V8 powered models and combines with specially devised chassis settings to ensure it excels on tarmac and loose surfaces - without compromising its unstoppable off-road capability.



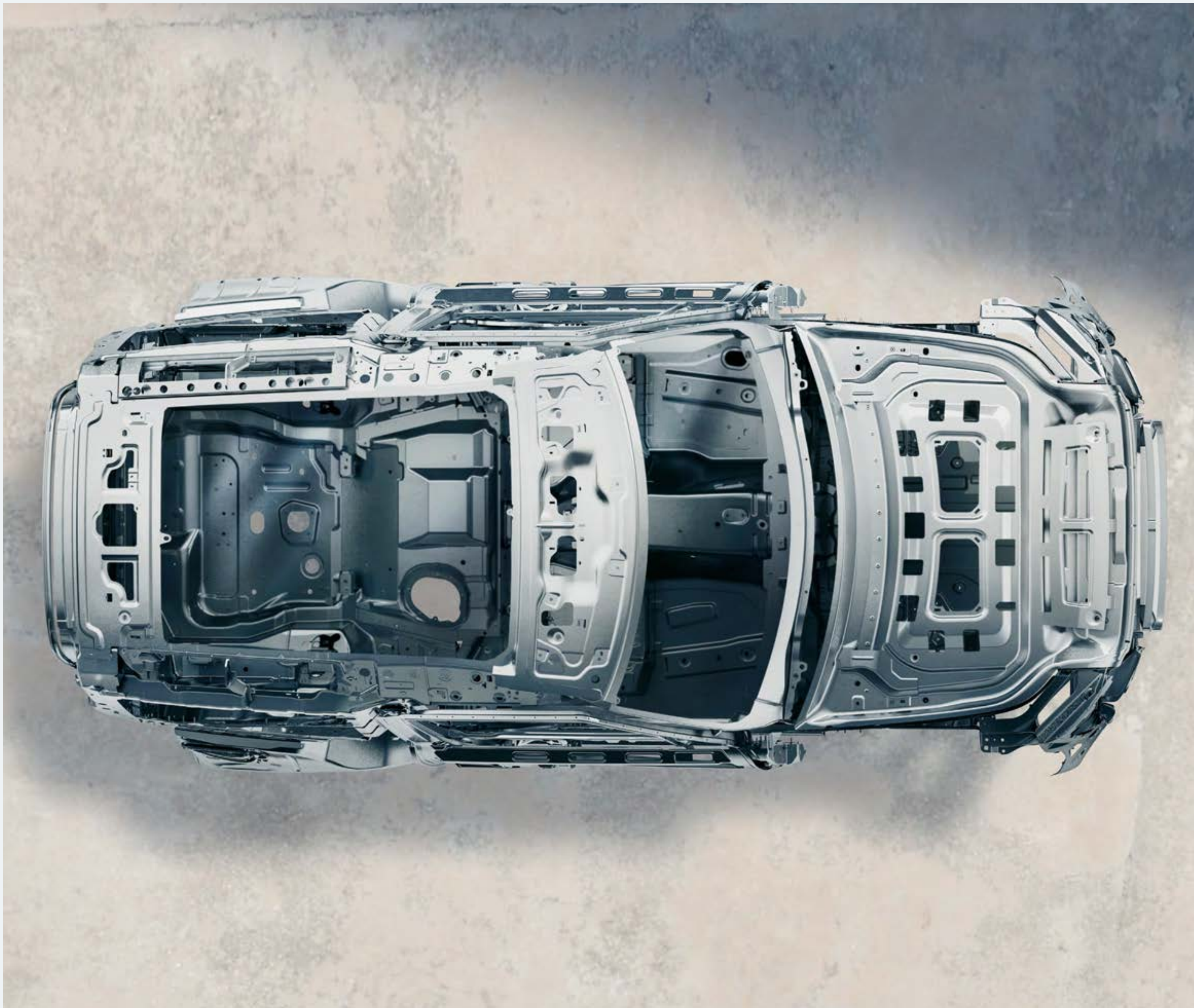

STRONG AND TOUGH BODY STRUCTURE

To retain the famous Defender silhouette, accommodate a family of body designs and support the latest range of electrified powertrains, Land Rover developed the all-aluminium D7x platform. It has the unique combination of practicality, flexibility and capability expected from a 4x4 wearing the Defender name. This commitment to engineering integrity means the Defender has its own line in body assembly at the manufacturing facility in Nitra, Slovakia.

By raising the body height and cleverly locating elements including the battery and cooling circuits, Land Rover's engineers have delivered ultra-short front and rear overhangs, which guarantee impressive approach and departure angles of 38 and 40 degrees respectively on the 90 and 110. With a wheelbase of 3,022mm (99mm longer than a Discovery) the 110 has a breakover angle of 28 degrees (31 degrees for the 90) ensuring excellent off-road geometry³.

The short rear overhang, the same for both 90 and 110, is made possible by mounting the spare wheel externally, where it is readily accessible off-road, rather than under the rear floor, and the trademark side-hinged rear door is engineered to accommodate any of the available wheel and tyre combinations.

The comprehensive choice of 18-, 19-, 20- and 22-inch wheels range from utilitarian 18-inch Gloss White Steel rims to 22-inch Satin Dark Grey alloy designs. With All-Season or Off-Road tyres available, all with an outside rolling diameter of 815mm, the Defender is available with a large contact patch for peerless traction and grip in any environment. Specialist Professional Off-Road tyres are available through retailers in selected markets, for customers who need the ultimate capability and robustness.

The inherent strength of the Defender's structure is highlighted by its impressive five-star score of the 110 in Euro NCAP testing. The strong and intelligently designed bodyshell's ability to effectively absorb energy in a collision resulted in the testers awarding it an impressive 89 per cent for adult and child protection.

SOPHISTICATED CHASSIS

The monocoque body developed for Defender is able to withstand 6.5 tonnes of snatch load through the recovery points. This strong, stiff structure provides the perfect foundation for the 4x4's advanced all-independent chassis.

The sophisticated double wishbone front and integral link rear suspension optimises off-road performance while delivering excellent handling dynamics and comes with a choice of passive coil or Electronic Air Suspension on both 90 and 110 derivatives. The 130 features Electronic Air Suspension as standard for superior all-terrain capability and driver confidence in all environments.

The suspension layout uses bespoke components to deliver world-class durability with steel subframes and uprated ball joints and bushes that are designed to withstand severe off-road impacts - the wheels can withstand up to seven tonnes of vertical load into the body. As a result, Defender delivers an unmatched breadth of capability, combining long-haul cruising comfort and rewarding handling characteristics with immediate responses and peerless off-road performance.

Adaptive Dynamics is available with Electronic Air Suspension, allowing customers to fine-tune the driving characteristics. The system's adaptive dampers monitor body movements up to 500 times per second and respond almost instantaneously to optimise control and comfort.

Air suspension helps to transform the 4x4's on-road handling and supports its all-terrain capability, providing an off-road ride height lift of 75mm and supreme ride comfort across all surfaces. An additional 70mm of lift means the air system can raise the body by a maximum of 145mm when needed, while Elegant Arrival automatically lowers the body by 40mm to aid access.

The confidence-inspiring and sure-footed Defender excels off-road, where its maximum suspension articulation of 500mm comes into its own. It can tackle 45-degree side slopes and inclines of 45 degrees with customary composure, but the biggest transformation comes on the road, where the Defender is engaging and agile.

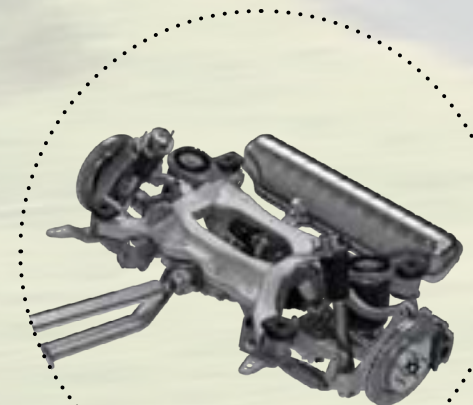

SUBFRAMES

Reinforced steel subframes help create an incredibly strong structure that delivers a comfortable and assured drive, while also ensuring the durability required for Defender.



AIR SUSPENSION

Fully independent air suspension irons out any bumps in the road, as well as raising the vehicle to get over extreme obstacles and lowering it for easy entry and egress.

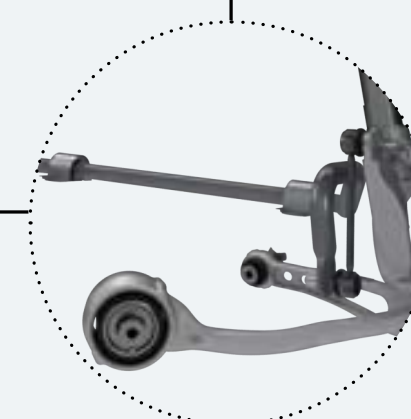

MULTI-LINK SUSPENSION

A stiff multi-link suspension delivers great refinement on the road. It allows more control over longitudinal and lateral movements ensuring absolute confidence no matter the surface.



DIFFERENTIAL CONTROLS

The electronic centre and rear differentials automatically react to changes in the surface conditions, ensuring maximum capability and performance is maintained when driving on and off-road.

BREADTH OF CAPABILITY

A transformational breadth of capability sets Defender apart. Intelligent All-Wheel Drive and a twin-speed automatic gearbox, centre differential and optional Active Locking Rear Differential² ensure it has all the hardware required to excel in the soft sand of the desert, the freezing tundra of the arctic and everywhere in between.

Intelligent All-Wheel Drive (iAWD) is fitted to all Defender models as standard and enhances on-road performance and off-road capability, while delivering improved efficiency. By continually varying axle torque to suit the conditions using sensor data from the vehicle surroundings and driver inputs, it can distribute all torque to one axle or the other as required.

This intelligent and proactive torque distribution optimises traction, on-road dynamics and efficiency, resulting in improved fuel economy and reduced CO₂ emissions - all without sacrificing any of the Defender's inherent off-road capability.

Defender V8 combines exceptional off-road capability with uniquely engaging dynamics on the road and across loose surfaces. Engineered to be the fastest and most dynamic Defender ever, it features a number of enhancements aimed at improving performance and delivering the ultimate in drivability.

Careful calibration of the new Dynamic program gives Defender V8 a more agile, playful and responsive character in 90 and 110 body designs. In this setting, a sharper throttle response and bespoke tuning for the Continuously Variable Damping combine with the stiffer suspension bushes for immediate steering responses. Working in harmony with the Torque Vectoring by Braking technology, Traction Control Systems and new Yaw Controller for the Electronic Active Rear Differential, the Defender V8 is faster, more engaging and more controllable than ever.

In addition, the use of larger diameter and solid anti-roll bars help reduce body roll in extreme cornering, while the Yaw Controller allows fine control of the Defender V8's attitude as it reaches and exceeds the limit of grip. Crucially, none of these changes come at the expense of off-road capability.

All Defender 130 models feature Electronic Air Suspension with Adaptive Dynamics for unrivalled all-terrain capability and driver confidence in all environments. The Electronic Air Suspension system allows for up to 430mm of articulation and, in Off-Road Height, Defender 130 shares the same maximum wading depth of 900mm as the rest of the family.



TERRAIN RESPONSE®

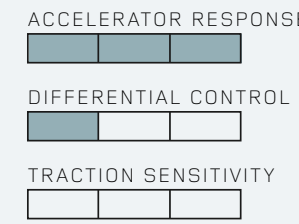
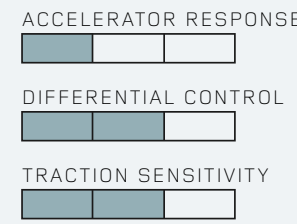
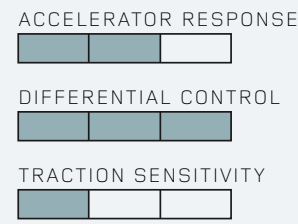
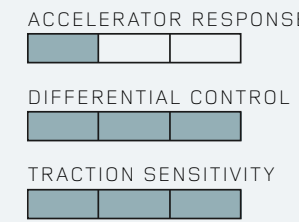
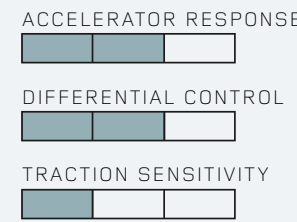
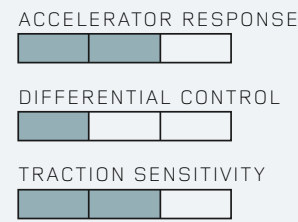

CONFIGURABLE TERRAIN RESPONSE

Defender features a series of technologies to help deliver the capability customers expect, including the latest generation of Land Rover's patented Terrain Response® system. Configurable Terrain Response technology allows drivers to use the touchscreen of Pivi Pro infotainment to fine-tune every aspect of the vehicle to suit its precise surroundings.

In the original Defender, drivers could lock the central differential manually using the high-to-low range gear selector. In new Defenders, drivers can prevent cross-axle slip using the Centre Slip Limited and Centre and Rear Slip Limited options on the central touchscreen controller. In addition, there is a choice of three settings for the throttle and gearbox response, steering and traction control, allowing experienced off-roaders and all-terrain novices to tailor the vehicle set-up to suit their requirements.

The system allows four individual profiles to be saved, so different drivers can quickly activate their preferred settings. Alternatively, the intelligent Auto functionality of Terrain Response 2® can recognise the surface and configure the vehicle appropriately with no input from the driver.

The Defender also features a Wade programme within the Terrain Response 2® menu. It automatically softens the throttle response, sets the heating and ventilation to recirculate cabin air, locks the driveline and adjusts the ride height to its off-road setting while activating the Wade Sensing screen on the infotainment system. This allows drivers to see the depth of surrounding water and provides ultimate confidence when fording deep water - allowing drivers to take full advantage of Defender's world-class maximum wading depth of 900mm.

Land Rover's advanced All-Terrain Progress Control and ClearSight Ground View² technologies also support drivers in extreme off-road situations, removing the stress of maintaining a low crawl speed and showing the hidden area directly in front of the vehicle using the central touchscreen.

CONFIGURABLE TERRAIN RESPONSE PIVI SCREEN





TOWING & CARRYING

The Defender's strong body architecture helps customers make more of their world, whether they want to tow heavy loads or carry them, with a comprehensive range of roof racks and tow bar systems, and a maximum towing capacity of 3,500kg⁴. State-of-the-art technologies include Advanced Tow Assist, which takes the stress out of difficult reversing manoeuvres by letting drivers steer trailers with their fingertips using a rotary controller on the central console. The intelligent set-up works with 3D visualisation on the central touchscreen.

The ultra-strong body is ready for overland adventures, with a maximum roof load of 168kg making it perfectly suited to both camping trips and visits to the hardware store⁵. The 300kg¹² maximum static roof load allows adventurous souls to make use of the expedition-ready pop-up roof tent⁹ accessory, turning Defender into an all-terrain home from home. Defender 130 provides towing capacity of up to 3,000kg⁴, while hitching is made easier with the Electronic Air Suspension system that can be controlled via a switch panel inside the tailgate to raise and lower the vehicle to meet a towing hitch.

VERSATILE LOADSPACE

The rear loadspace delivers customary Defender practicality with the 110 providing up to 1,075 litres when using the full height. Folding the row-two seats provides a generous maximum load volume of up to 2,380 litres and, with a maximum payload of up to 900kg (110 P400), the New Defender lives up to the practical heritage of its iconic predecessors⁶.

Defender 130 provides a spacious and practical load area, with up to 389 litres of cargo volume even with the row three seats in place, while the five-seat version of Defender 130 offers a vast load area of up to 2,516 litres with row two folded.

On eight-seat models, the third-row seats fold to create a large loading area when not in use, giving customers the ultimate choice in how they configure the interior. They are split in 40:20:40 for added convenience.

The second-row seatbacks are split 40:20:40 for maximum flexibility, while loadspace rails on the floor of the luggage space come with a range of load retention accessories to prevent smaller items from moving around inside. A lockable Security Box provides added protection on overland adventures - the heavy-duty steel box secures to the loadspace rails and is big enough to hold laptops, tablets and other valuables³. In addition, all Defenders feature a lockable 5.8-litre glovebox and deep door pockets. The exposed cast metal Cross Car Beam also doubles as a shelf to provide 6.9 litres of open oddment stowage.

| LOADSPACE VOLUMES | 90 (FIVE-SEAT) | 110 (FIVE-SEAT) | 110 (5+2 SEAT) | 130 OUTBOUND | 130 (EIGHT-SEAT) |
|--|----------------|-----------------|----------------|--------------|------------------|
| MAX. LOAD CAPACITY, BEHIND ROW THREE (TO THE ROOFLINE) | n/a | n/a | 231 litres | n/a | 389 litres |
| MAX. LOAD CAPACITY, BEHIND ROW TWO (TO THE WAISTLINE) | 240 litres | 543 litres | 464 litres | 667.9 litres | 588 litres |
| MAX. LOAD CAPACITY, BEHIND ROW TWO (TO THE ROOFLINE) | 397 litres | 1,075 litres | 916 litres | 1,329 litres | 1,232 litres |
| MAX. LOAD CAPACITY, ROW TWO SEATS FOLDED (TO THE ROOFLINE) | 1,563 litres | 2,380 litres | 2,233 litres | 2,516 litres | 2,291 litres |



THE PERFECT COMPANION

Defender has always been the perfect companion for outdoor adventures and the new model is no different. The clip-in loadspace cover is designed to double as a ground mat for picnics or when changing mucky footwear on wet surfaces. The hose-clean and machine washable material is another example of Defender's rugged and practical design. In addition, 90 and 130 body designs can be specified with an additional loadspace tray¹³ that allows owners to maximise boot space with flexible, configurable storage and a flat loading area.

The versatile loadspace is both big and clever. A switch panel inside the rear door allows customers to adjust the rear ride height of the Electronic Air Suspension and operate the deployable towbar, for simple trailer hitching, when fitted.

Reinventing and updating the hose-clean interior of old Series and Defender models, Defender 90 and 110 also feature a durable rubber floor with flush sills, allowing customers to brush or wipe the interior clean after muddy or dusty adventures. Customers can specify carpet inserts for a more premium look and feel (standard on Defender 130), but these are easily removed to reveal the durable flooring beneath when necessary.



NEXT-GENERATION BRAKING PERFORMANCE

Defender features next-generation braking technology which provides quicker and quieter responses than conventional systems, improving safety and enhancing the driving experience. An actuator-controlled piston operated by the foot pedal applies braking effort, delivering much finer control.

The system comes into its own during low-speed off-road manoeuvres and, when the Traction Control and Autonomous Emergency Braking systems are triggered, it can lock a wheel within only 150 milliseconds - versus 300 milliseconds with a conventional set-up.

In everyday use, the benefits include Hill Launch Assist with Enhanced Hill Hold, so the vehicle is prevented from rolling back on inclines - leaving the driver to focus solely on pulling away and negotiating objects ahead - with a smoother transition from the brakes to power in all environments.





TESTED TO EXTREMES

Defender is truly capable of great things and the front and rear recovery points can withstand up to 10 and nine tonnes of pull respectively. During its global development programme, Land Rover engineers were able to complete iconic trails in Moab, USA, for the first time, including Hell's Revenge, the Poison Spider and the Steel Bender Trails. Closer to home, the Defender met Land Rover's toughest durability standards during testing at the global design and engineering headquarters at Gaydon. As part of these extreme events, the Defender withstood repeated 200mm kerb strikes at 40km/h (25mph).

| CAPABILITY IN NUMBERS | DEFENDER 90 | DEFENDER 110 | DEFENDER 130 |
|------------------------------------|---------------------------------------|---|---|
| LENGTH | 4,323mm (4,583mm with spare wheel) | 4,758mm (5,018mm with spare wheel) | 5,098mm (5,358mm with spare wheel) |
| WIDTH | 2,008mm (door mirrors folded) | | |
| HEIGHT | 1,969mm | 1,967mm | 1,970mm |
| WHEELBASE | 2,587mm | 3,022mm | |
| TURNING CIRCLE | 11.3m | 12.84m | |
| FRONT OVERHANG | 845mm | | |
| REAR OVERHANG | 890mm (1,151mm with spare wheel) | | 1,230mm (1,491mm with spare wheel) |
| APPROACH ANGLE | 38 deg | | 37.5 deg |
| DEPARTURE ANGLE | 40 deg | | 28.5 deg |
| BREAKOVER ANGLE | 31 deg | 28 deg | 27.8 deg |
| GROUND CLEARANCE | 291mm | 291mm | 290mm |
| ARTICULATION | 500mm | 500mm | 430mm |
| MAXIMUM WADING DEPTH | 900mm | | |
| MAXIMUM ROOF LOAD | 118kg / 300kg ⁵ | 168kg / 300kg (dynamic / static) ⁵ | |
| MAXIMUM TOWING WEIGHT ⁴ | 3,500kg | 3,500kg | 3,000kg |
| MAXIMUM PAYLOAD | 800kg (90 P300) | 900kg (110 P400) | Up to 750kg (8 seats); Up to 800kg (Outbound) |

TECHNOLOGY

DEFENDER

TECHNOLOGY





PIVI PRO INFOTAINMENT

Consumer technology has also driven the development of Jaguar Land Rover's fastest and most intuitive infotainment system. The award-winning Pivi Pro set-up is inspired by the latest smartphones and accessed through a central touchscreen that features a 10- or 11.4-inch display². Its always-on design ensures instant responses, even when starting the vehicle for the first time.

Supported by a built-in back-up battery, navigation initialisation takes just seconds while an easy-to-follow menu structure ensures customers can carry out the most common tasks directly from the home screen, reducing driver distraction. The easily customised and redesigned layouts reduce the number of steps by an average of 50 per cent versus previous systems and incorporate Apple CarPlay™ and Android Auto® for intuitive smartphone integration. Its Bluetooth technology can even connect to two smartphones simultaneously while Wireless Device Charging with a signal booster is available for enhanced convenience and call quality.

The navigation system uses self-learning algorithms and dynamic guidance to optimise routing, while Smart Voice Guidance even knows to cancel audio instructions when drivers are travelling in familiar surroundings. Maps will always be up to date thanks to the SOTA technology⁸. In combination with the 12.3-inch Interactive Driver Display, the advanced system provides high-definition 3D mapping within the instrumentation, leaving the central touchscreen free to control other applications.

For superior navigation and location-finding, Defender integrates what3words, giving customers accurate and precise navigation in the most remote environments. what3words is a British technology company that has divided the globe into a grid of 57 trillion 3m x 3m squares, each with a unique, easy-to-remember three-word address, so you can reach your precise destination even in remote areas without connectivity.

The integrated technology allows what3words addresses to be inputted directly to the navigation bar of the Pivi Pro infotainment or via the connected car app, working seamlessly alongside the existing HERE connected navigation and mapping software.

Customers will be able to navigate precisely to any location in the world, faster and more conveniently than ever using just three words - whether finding the perfect place to explore off-road, locating an individual parking space or identifying a specific site entrance or meeting place.

DRIVER TECHNOLOGY

Ahead of the driver, high-resolution digital instruments can be configured to show a pair of conventional dials, full-screen 3D navigation guidance or a combination of the two, allowing drivers to optimise the display to suit the circumstances and their individual preference.

Customers can even keep tabs on the Defender from afar, using Land Rover's Remote tracking technology, which allows owners to monitor its location, fuel level, lock and unlock the vehicle and even initiate the climate control to heat or cool the cabin before setting off.

Driver distractions are kept to the absolute minimum with the Head-up Display (HUD). The full-colour backlit TFT set-up provides key information to the driver, while its new video capability can replicate displays from the central touchscreen – including articulation graphics to assist the driver in off-road environments.

The Pivi Pro infotainment also operates Cabin Air Purification Plus, which is available across the Defender family and fitted to Defender 130 as standard. It enhances cabin air quality for occupants using a variety of technologies, including nanoe™ ionisation, PM2.5 Cabin Air Filtration and CO₂ Management, which monitors interior and exterior air and adjusts accordingly, ensuring occupants experience the best available air quality.

Advanced nanoe™ X technology is scientifically proven to significantly reduce viruses and bacteria, and the Purge function allows customers to prime the cabin prior to departure remotely, using their smartphone, to ensure optimum air quality from the very beginning of every journey. Three-Zone Climate Control (Four-Zone Climate Control on the 130) systems also ensure occupants in any available seating position will enjoy the perfect temperature.



ADVANCED DRIVER ASSISTANCE

Land Rover's new Electrical Vehicle Architecture, state-of-the-art forward-facing digital camera, advanced ultrasonic sensors and powerful 3Gbit/s onboard network support a comprehensive suite of driver assistance technologies, with the cameras and sensors governed by a single integrated processor, or domain controller, for optimised security.

These include a 3D Surround Camera that provides both 360-degree plan and new 3D exterior perspective views of the surrounding area, both off- and on-road. The advanced system provides enhanced augmented on-screen visualisation when using Tow Sensing, Wade Sensing and Land Rover's ClearSight Ground View² transparent bonnet technology, to improve visibility.

To maintain rearward visibility, all Defenders fitted with the front jump seat and all 130 models also feature ClearSight Rear View technology. At the touch of a button, the frameless interior mirror switches from a conventional mirror to a digital screen showing a feed provided by a high-definition rear-facing camera mounted high at the back of the vehicle.

The clever technology effectively makes the rear pillars and spare wheel - and any objects inside the vehicle - invisible, while also providing a 50-degree wider field of vision to eliminate rear blindspots. The 1.7-megapixel camera also provides superior clarity in low light conditions and has a hydrophobic coating to maintain performance in wet and muddy conditions.

A Driver Assist Pack includes Adaptive Cruise Control and Rear Pre-Collision Monitor, which alerts following drivers who are failing to slow down by automatically flashing the hazard lights, as well as Blind Spot Assist², Rear Traffic Monitor and Clear Exit Monitor. This impressive tally of features helped the New Defender 110 record a five-star Euro NCAP score, with an impressive 79 per cent rating for the Safety Assist systems.

The comprehensive list of driver assistance technologies includes Emergency Braking, Lane Keep Assist, Traffic Sign Recognition, Cruise Control and Speed Limiter functions, a Driver Condition Monitor and front and rear Parking Aids, while the advanced chassis control features are supported by an ultra-fast Flexray network. Customers can also choose from six-speaker, and 10- and 14-speaker (both plus subwoofer) Meridian™ sound systems delivering 180W, 400W or 700W of amplifier power, providing rich sound quality for all occupants.



STAY CONNECTED

A comprehensive supply of charging sockets throughout the cabin keeps occupants charged and connected at all times, whether using digital devices to stream music or camping accessories to provide home comforts in remote locations. Front-row occupants can choose from a pair of 12V power supplies and two USB sockets, one of which is located behind the central touchscreen – perfectly located to minimise trailing wires. In addition, a wireless charging pad allows quick and convenient device charging, while a signal booster ensures strong network connection.

In the second row, occupants have two USBs and a pair of 12V charging points and, when third-row seats are fitted, they come with a USB outlet and 12-volt socket. The loadspace also includes an additional 12-volt socket while a three-pin 230V domestic socket is also available.

Thoughtful touches include the availability of USB sockets on the front seatbacks, specifically positioned to allow second-row occupants to charge devices while using the optional Click and Go² tablet holders.





SECURE AND CONVENIENT KEY TECHNOLOGY

State-of-the-art keyless technology brings added cyber security and convenience with advanced Ultra Wide Band (UWB) transceivers preventing thefts from copycat devices. Jaguar Land Rover was the first vehicle manufacturer to introduce the pioneering keyless entry system and Defender uses the innovative set-up to resist relay attack and meet the world's toughest security standards.

The second-generation Activity Key can be specified in addition to the pair of standard fobs for heightened convenience. The water resistant (4 ATM) and shock-proof wearable device now incorporates an LCD watch. The wrist-worn device allows customers to unlock any door, lock or start the vehicle - doing away with the electronic 'handshake' previously required to lock or unlock the vehicle. Instead, customers can access or secure the Defender either using a button on the watch screen or its keyless entry functionality.

The powerful D300 produces 650Nm of torque and powers the Defender from 0-60mph in 6.3 seconds (0-100km/h in 6.7 seconds) for the Defender 90, with fuel economy of up to 32.2mpg (8.8l/100km) and emissions from as low as 230g/km¹. All six-cylinder diesel engines feature state-of-the-art MHEV technology to harvest energy lost under deceleration and braking to boost fuel efficiency. A belt-integrated starter motor ensures more responsive and refined operation of the start-stop system and provides extra assistance to the engine when accelerating.

In combination with the MHEV system, the six-cylinder diesels also feature lightweight aluminium construction and a pair of close-coupled, sequentially arranged turbos to maximise heat delivered to the catalyst to reduce the time it takes to warm up, optimising efficiency. State-of-the-art low friction steel pistons also contribute to improved efficiency over previous diesel engines, while variable nozzle turbo technology ensures 90 per cent of peak torque is delivered in just over a second at 2,000rpm.

Petrol Defender 90 and 110 customers can choose between P425 MHEV powertrain and the Defender V8, badged P525.



The powerful P525¹¹ Defender V8 offers the ultimate combination of power and capability using Land Rover's 5.0-litre V8 supercharged petrol engine. It provides blistering performance, making this the fastest production Defender ever made.

With 525PS at 5,500rpm and 625Nm at 2,500rpm, the Defender 90 accelerates from 0-60mph in 4.9 seconds (0-100km/h in 5.2 seconds) - the Defender 110 takes 5.1 and 5.4 seconds respectively. Where conditions allow, the top speed is 149mph. Extensive acoustic tuning of the New Defender V8's induction and exhaust systems result in a rich and authentic V8 soundtrack.

All engines drive through a smooth and responsive eight-speed ZF automatic gearbox and twin-speed transmission, to provide a set of low-range ratios essential for towing or off-road driving when more control is required.





DEFENDER 130

Defender 130 is available with a choice of electrified powertrains, including P300 and P400 mild-hybrid Ingenium six-cylinder petrols, and the D250 and D300 Ingenium six-cylinder diesels.

The P300 delivers effortless, refined performance, accelerating from 0-60mph in 7.5 seconds (0-100km/h in 8.0 seconds), while the P400 achieves 0-60mph in 6.3 seconds (0-100km/h in 6.6 seconds).

The Ingenium diesel engines provide enhanced torque delivery, smooth responses and superior fuel economy, with a 0-60mph in 7.1 seconds (0-100km/h time of 7.5 seconds) for the D300. The D250 provides 250PS and 600Nm of torque and is capable of accelerating from 0-60mph in 8.4 seconds (0-100km/h in 8.9 seconds).

Providing effortlessly strong performance is the Defender 130 V8. With 500PS and 610Nm of torque, it has been engineered to suit the 130's refined character across all terrains and accelerates from 0-60mph in 5.4 seconds (0-100km/h in 5.7 seconds).



DEFENDER

ACCESSORIES



MAKE MORE OF YOUR WORLD WITH THE MOST ACCESSORISED AND PERSONALISED LAND ROVER

Personal experiences and adventures are part of the Land Rover landscape and Defender maintains this rich heritage, allowing customers to personalise their vehicle to fit their lives with more choice than ever before.

The most accessorised and personalised Land Rover ever produced is available in 90, 110 and 130 body designs and Defender X-Dynamic levels, while customers can choose from a range of four Accessory Packs to give the rugged new 4x4 a unique character. This is in addition to S, SE and HSE Specification Packs available for Defender and X-Dynamic customers.

The Extended Black Pack is available on Defender X-Dynamic and V8 derivatives and provides an extension to the existing Black Pack for an even stealthier appearance.

Available on all Defender models, the Bright Pack features a Noble Chrome finish on the front and rear skid plates, grille bar and badging. The Extended Bright Pack adds Ceres Silver to the lower body cladding and wheel arches.

Those looking for enhanced personalisation on Defender 90 and 110 can specify the new County¹⁴ Exterior Pack. Inspired by the original Defender County, it features unique exterior elements, with a modern interpretation designed to celebrate the 4x4's heritage.

A choice of 100 individual accessories means the chances of finding two identical Defenders is remote, while Land Rover's new Above and Beyond Collection of outdoor performance apparel and equipment delivers the same durability and toughness as Defender. The full range of official accessories is available individually, but four Accessory Packs help customers to tailor Defender to suit their lifestyle:



EXPLORER PACK

Conquer unmapped extremes with a Raised Air Intake, lightweight 26kg Expedition Roof Rack⁵ and an Exterior Side-mounted Gear Carrier. Front and Rear Classic Mud Flaps, Wheel Arch Protection and a Spare Wheel Cover provide extra ruggedness while a Matte Black bonnet decal, featuring 90 or 110 cut-out detailing, completes the Explorer Pack's head-turning appearance.

Customers can also upgrade the Explorer Pack with Fixed Side Steps and a Deployable Roof Ladder, while the Front Expedition Protection System adds a Front Undershield and 'A'-Frame Protection Bar with raised corners to improve the front approach angle.

The Explorer Black Pack features all the equipment from the Explorer Pack, with a stealthy gloss black finish for the Gear Carrier, Wheel Arch Protection, side steps and rear scuff plate - with black chequer detail.



ADVENTURE PACK

A Portable Rinse System with a 6.5-litre pressurised water reservoir, boot-mounted Integrated Air Compressor and Exterior Side-mounted Gear Carrier equip Defender for time spent in the wilds. Protection is enhanced by Front and Rear Mud Flaps, a Spare Wheel Cover and a Bright Rear Scuff Plate, to guard the rear bumper against scrapes and scratches when loading and unloading, while a practical 20-litre Seat Backpack, which you can take with you when you leave the vehicle, completes the interior. The Adventure Black Pack is also available for gloss black elements similar to the Explorer Black Pack.



COUNTRY PACK

Designed for time spent off the beaten track, the Country Pack features rugged Wheel Arch Protection, a Bright Rear Scuff Plate to protect the top of the rear bumper and Front and Rear Classic Mud Flaps. A Portable Rinse System and Full-Height Loadspace Partition equip the interior for everyday adventures.



URBAN PACK

To stand out in the concrete jungle, the Urban Pack adds a Bright Rear Scuff Plate, Spare Wheel Cover and Front Undershield while Bright Metal Pedals add to the robust interior. Customers can then opt for a range of alloy wheel upgrades including a distinctive 22-inch five-spoke design.

A selection of Side Tubes and both Fixed or Deployable Side Steps are available across all four Accessory Packs alongside a full range of durable deep-sided rubber mats to protect the interior.

The comprehensive range of accessories can also be purchased separately, including the innovative Exterior Side-mounted Gear Carrier, which aligns with the Defender's distinctive floating pillars² and is perfect for holding mucky equipment. The lockable stowage pod has been aerodynamically tested to minimise wind noise and withstand extreme conditions and its 24-litre capacity can support up to 17kg, making it perfect for storing muddy boots or soggy wetsuits, without soiling the interior.



EXPEDITION-READY

If the Gear Carrier isn't fitted, Defender's floating pillars also provide a home for the Deployable Roof Ladder, which folds down from its locked position to allow easy access to items being carried on the roof. With a choice of Aqua Sports Carriers, Roof Rails and Roof Racks, customers can make full use of Defender's impressive 168kg⁵ maximum dynamic roof load.

For overnight camping trips and overland adventures, a Rooftop Tent⁹ makes full use of Defender's maximum static roof load of 300kg. Its one-click operating mechanism is easy-to-use and, when fitted with the Deployable Roof Ladder and Expedition Roof Rack, New Defender doubles as all-terrain accommodation for remote camping trips.

ADDITIONAL ACCESSORIES

The Portable Rinse System includes a 6.5-litre reservoir, hose and shower attachment and can be used to clean everything from dirty kit to filthy dogs and is also available as part of Land Rover's existing Pet Packs. The user-friendly and practical list of standalone accessories also includes an Inflatable Waterproof Awning and a range of towing systems.

To ensure the toughest and most capable member of the Land Rover family inspires complete confidence in the most inhospitable environments on earth, a Remote Control Electric Winch provides complete assurance even when miles from home. Packaged neatly within the front bumper, its integrated design generates a maximum force of 4,536kg, holds 24m of synthetic rope and can be wirelessly operated up to 45m away for the ultimate convenience and safety off-road.

Raised Air Intakes are a vital addition in dusty locations, protecting the engine by delivering cleaner air from their elevated position, and the Defender is available with a close-fitting semi-integrated design that fits neatly onto the side-mounted engine air intake in the front fender, to preserve performance in dusty environments.

An intuitive online configurator lets customers personalise their New Defender quickly and easily - to see how your perfect specification looks, go to: www.landrover.com/Defender





APPENDIX

¹ All fuel consumption and CO2 data quoted above relates to Official EU-WLTP TEL Combined Test Figures for five-seat derivatives. The figures provided are as a result of official manufacturer's tests in accordance with EU legislation. For comparison purposes only. Real world figures may differ. CO2 and fuel economy figures may vary according to factors such as driving styles, environmental conditions, load and accessories. PHEV not available on 130 & 90.

² Optional feature.

³ Measured in off-road height.

⁴ Max Towing Capacity Defender 90 & 110: 3,500kg, Defender 130: 3,000kg, (up to 8,200lbs in NAS).

⁵ 168kg roofload and expedition rack only available with off-road tyre. Must include weight of roof rack/rails rated at 36kg (110) / 30kg (90). Adventure and Explorer Pack excludes Defender V8.

⁶ All figures for five-seat configuration.

⁷ Range achieved will vary dependent on vehicle and battery condition, actual route and environment and driving style.

⁸ Self-learning car and navigation features will continue to be enhanced via Software Over The Air updates.

⁹ Autohome & Land Rover Partnership, only available on Defender 110 with Expedition Roof Rack, Autohome ladder provided.

¹⁰ In-car features should be used by drivers only when safe to do so. Drivers must ensure they are in full control of the vehicle at all times. Amazon Alexa Voice AI is only available in certain markets. Amazon, Alexa and all related logos are trademarks of Amazon.com, Inc. or its affiliates. Certain Alexa functionality is dependent on smart home technology. Use of Amazon Alexa requires an Amazon account.

¹¹ Defender 90 & 110 - 525PS; Defender 130 - 500PS.

¹² Off-road tyres only.

¹³ Available late 2023.

¹⁴ County Pack available on Defender 90 only in China market.



DEFENDER

SEURAAVAKSI